



EFFORTLESS COVERAGE™

Neo for Iwata TRN1 Gravity Feed Trigger Airbrush #N5500

Illustrated Parts Listing



Item#	Part No.	Description
1	N 1102	Needle Cap
2	N 1403	Nozzle Cap 0.35mm (N3)
3	N 0803	Nozzle 0.35mm (N3)
5	N 1353	Head Base
6	N 1505	Head Base Packing (PTFE)
7	N 1312	Main Body Ring Screw
8	N 1507	Needle Packing (PTFE)
9	N 1252	Needle Packing Screw
10	N 1301	Slide Cam
11	N 1302	Spring Side Cam
12	N 1311	Main Body Ring
13	N 1152	Needle Chucking Guide
14	N 1352	Needle Spring
15	N 1702	Needle Spring Guide
16	N 1202	Needle Chucking Nut
17	N 0753	Needle 0.35mm (N3)
18	N 0902	Handle Cap Set
19	N 1002	Trigger With Trigger Screw

Item#	Part No.	Description
20	N 0101	Air Piston Set
21	N 0202	Air Valve Set
22	N 1601	Grip Mount/Extension
23	N 1602	Grip
29A	N 0701	Fluid Gravity Cup w/O-ring 0.05 oz/1.50 ml
29B	N 0712	O-ring for Fluid Gravity Cup 0.05 oz/1.50 ml
30A	N 0702	Fluid Gravity Cup w/O-ring 0.24 oz/7 ml
30B	N 0713	O-ring for Fluid Gravity Cup 0.24 oz/7 ml
31	N 0954	Fluid Gravity Cup Lid 0.24 oz/7 ml
32	N1651	Spanner

Optional

To change from 0.35 mm to 0.5 mm, change the below 3 parts for optimum performance

2	N 1404	Nozzle Cap 0.5MM (N5)
3	N 0804	Nozzle 0.5MM (N5)
17	N 0754	Needle 0.5MM (N5)

See next Page for schematic

Available from:

Dixie Art Airbrush www.dixieart.com • 800.783-2612

NEO FOR IWATA — TRN1, TRN2

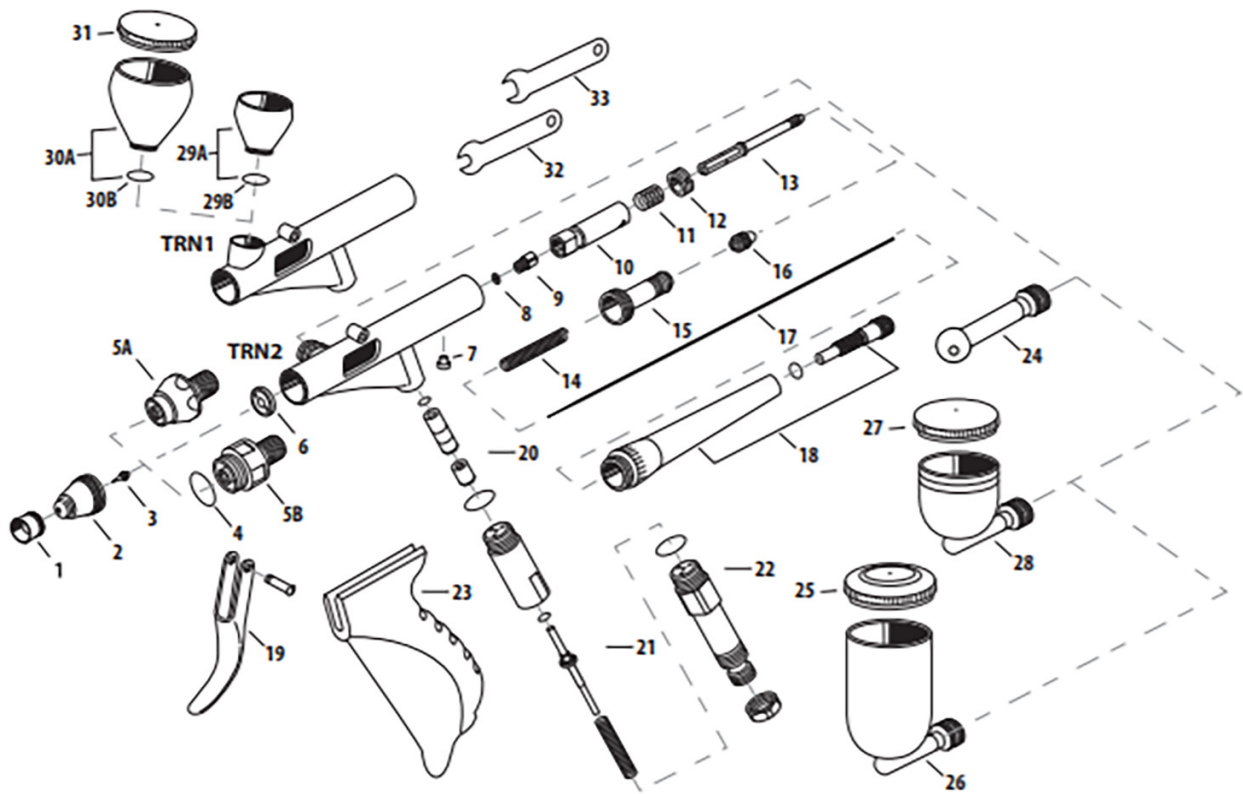

#	ITEM DESCRIPTION	PRICE CODE	ITEM #	TRN2 N 5000	TRN1 N 5500	ALSO FITS
1	Needle Cap	A	N 110 2	■	■	
2	Nozzle Cap	A	N 140 3	opt	■	
			N 140 4	■	opt	
3	Nozzle	C	N 080 3	opt	■	
			N 080 4	■	opt	
4	Nozzle Cap O-ring	A	N 150 4	■	x	
5A	Head Base	A	N 135 3	x	■	
5B	Head Base	A	N 135 4	■	x	
6	Head Base Packing (PTFE)	A	N 150 5	■	■	
7	Main Body Ring Screw	A	N 131 2	■	■	
8	Needle Packing (PTFE)	A	N 150 7	■	■	
9	Needle Packing Screw	A	N 125 2	■	■	
10	Slide Cam	A	N 130 1	■	■	
11	Spring Side Cam	A	N 130 2	■	■	
12	Main Body Ring	A	N 131 1	■	■	
13	Needle Chucking Guide	A	N 115 2	■	■	
14	Needle Spring	A	N 135 2	■	■	
15	Spring Guide	A	N 170 2	■	■	
16	Needle Chucking Nut	A	N 120 2	■	■	

#	ITEM DESCRIPTION	PRICE CODE	ITEM #	TRN2 N 5000	TRN1 N 5500	ALSO FITS
17	Needle	A	N 075 3	opt	■	
			N 075 4	■	opt	
18	Handle Cap Set	D	N 090 2	■	■	
19	Trigger With Trigger Screw	A	N 100 2	■	■	
20	Air Piston Set	A	N 010 1	■	■	
21	Air Valve Set	C	N 020 2	■	■	
22	Grip Mount/Extension	D	N 160 1	■	■	
23	Grip	B	N 160 2	■	■	
24	Bottle Adapter	C	N 040 1	■	x	
25	Side Cup Lid	A	N 095 2	■	x	
26	Side Cup	A	N 070 6	■	x	
27	Side Cup Lid	A	N 095 3	■	x	
28	Side Cup	D	N 070 5	■	x	
29A	Fluid Gravity Cup w/O-ring 0.05 oz / 1.50 ml	C	N 070 1	x	■	NEO CN
29B	O-ring For Fluid Gravity Cup 0.05 oz / 1.50 ml	A	N 071 2	x	■	NEO CN
30A	Fluid Gravity Cup w/O-ring 0.24 oz / 7 ml	D	N 070 2	x	■	NEO CN
30B	O-ring For Fluid Gravity Cup 0.24 oz / 7 ml	A	N 071 3	x	■	NEO CN
31	Fluid Gravity Cup Lid 0.24 oz / 7 ml	A	N 095 4	x	■	NEO CN
32	Spanner	A	N 165 1	x	■	NEO CN/ NEO BCN
33	Spanner	A	N 165 2	■	x	

■ = yes X = no opt = optional

Available from:

Dixie Art Airbrush www.dixieart.com • 800.783-2612