



AECR

Remote Feed Air Eraser with Quart Container

OPERATING INSTRUCTIONS AND REPLACEMENT PARTS

WARNING: Read instructions for proper care in handling and operation. Use in Well Ventilated Area to remove or trap dust. AE & AEX Compounds for External use **Only!** Paasche abrasives are listed as nuisance dusts. Consult the product label and Material Safety Data Sheet supplied for the material being sprayed. Secure air and material hoses wrench tight for safety and to prevent leaks. **MAXIMUM AIR PRESSURE 50 P.S.I.**

INTRODUCTION:

AECR Remote Feed Air Eraser with Quart Cup offers greater freedom of movement through use of a larger abrasive compound container which feeds abrasive by hose to the AECR Eraser. The large container allows the operator to work longer between refills.

The **AECR** Eraser is used by:

- Dental professionals to improve aesthetics of castings or obtain occlusal relationship analysis of gold castings.
- Hobbyists to etch decorative glass or quartz.
- Museums and Manufacturers to clean antique jewelry and fine parts.
- Lithographer to highlight halftones and erase defects without marring the surface or leaving a smudge.

The **AECR** Eraser can only be used with the following abrasive:

- **AEX-** Fast Cutting Compound

The most popular **AEX-** Compound has a particle size from 85 to 25 Microns, with an average 50 Microns.

OPERATION:

1. Connect A-1/8-6MT Air Hose Assembly as follows:
 - a. Small coupling nut to valve casing.
 - b. Large coupling nut to Air Supply.
2. Connect **AE-73** Hose Assembly to **AE-51** Cover Assembly. Make sure all connections are secure.
 - a. Small coupling nut to valve casing (#24).
 - b. Large coupling nut to outlet casing (#29).
 - c. The opposite end of the **AE-73** Hose Assembly should be attached to the **AECR** Eraser.
3. Fill **20SCC** Quart Cup (#30) with **clean dry abrasive** up to the fill line, as marked on illustration (page 2).
 - a. Make sure Gasket (#26) is properly placed in cover. Screw cover tightly back onto cup.
 - b. To prevent leakage, **do not** spill any abrasive on gasket or cup threads during assembly.
4. Regulate air pressure from 30 to 45 lbs. depending on the speed and abrasive action desired. The higher the pressure the faster the cutting action. **Do Not Exceed 50 lbs. Air Pressure.**

5. Hold **AECR** Remote Feed Air Eraser between thumb and index finger, similar to holding a pencil.
 - a. Move the Eraser over work surface, with the Tip w/Carbide Insert about 1/8" to 1/2" from surface.
 - b. For fast aggressive work, use **AEX-** Abrasive at maximum pressure of 45 lbs.

IMPORTANT ADJUSTMENTS:

If **AECR** Eraser should become clogged check the following:

1. Turn off air pressure, unscrew cover from cup, and remove compound from cup. Then screw cover on cup. Turn air on at low volume.
2. Remove Tip, clean tip by blasting it with air.
3. Blow air through shell **AE-70** and **AE-73** Hose Assembly to make sure they are clear.
4. If all of the above items are clear, turn off air pressure and remove cover. Refill container and replace cover then turn on air at source and continue working.

AECR Remote Feed Eraser comes complete with the following:

- **AECR** Eraser
- **A-1/8-6** Air Hose
- **AE-73** Hose Assembly w/Handle & Fittings
- **AE-51** Cover Assembly w/Fittings
- **3-GT** Gasket
- **20CC** Quart Cup

OPTIONAL ITEMS:

- **HF592** Adapter
- **HF-33** Couplers (2)
- **A-1/8-6MT** Air Hose w/MT Moisture Trap
- **R-75** Regulator w/ Gauge & Water Filter

NOTE: Parts are subject to wear due to nature of material being used.

AVAILABLE COMPRESSORS

D200R Air Compressor 1/6 HP, 110V., 60 Hz, 1.5 AMP., 7CFM@ 20 psi. Delivers 30 to 40 psi operating pressure.

DC850R Air Compressor 3/4 HP, 120V., 60Hz, 5.5 AMP., 2.40 CFM@40 psi. Delivers 30-75 psi operating pressure

ETCHING COMPOUND RECOMMENDATION

COMPOUND	APPROXIMATE CUP FILL LEVEL	AIR PRESSURE
AEX	1/4 TO 3/4 FULL	30 TO 45 P.S.I.
PUMICE	1/2 TO 3/4 FULL	30 TO 45 P.S.I.
STARCH	3.4 FULL	40 TO 45 P.S.I.

Paasche Airbrush Company
 4311 North Normandy Avenue
 Chicago, IL 60634-1395
 Phone: 773-867-9191 • Fax: 773-867-9198
 Website: paascheairbrush.com
 E-Mail: info@paascheairbrush.com

CAUTION: Do Not Exceed 50 P.S.I. Pressure. To do so may require replacement of the 20SCC Cup and create an unsafe condition.

NEW - AECR Air Eraser

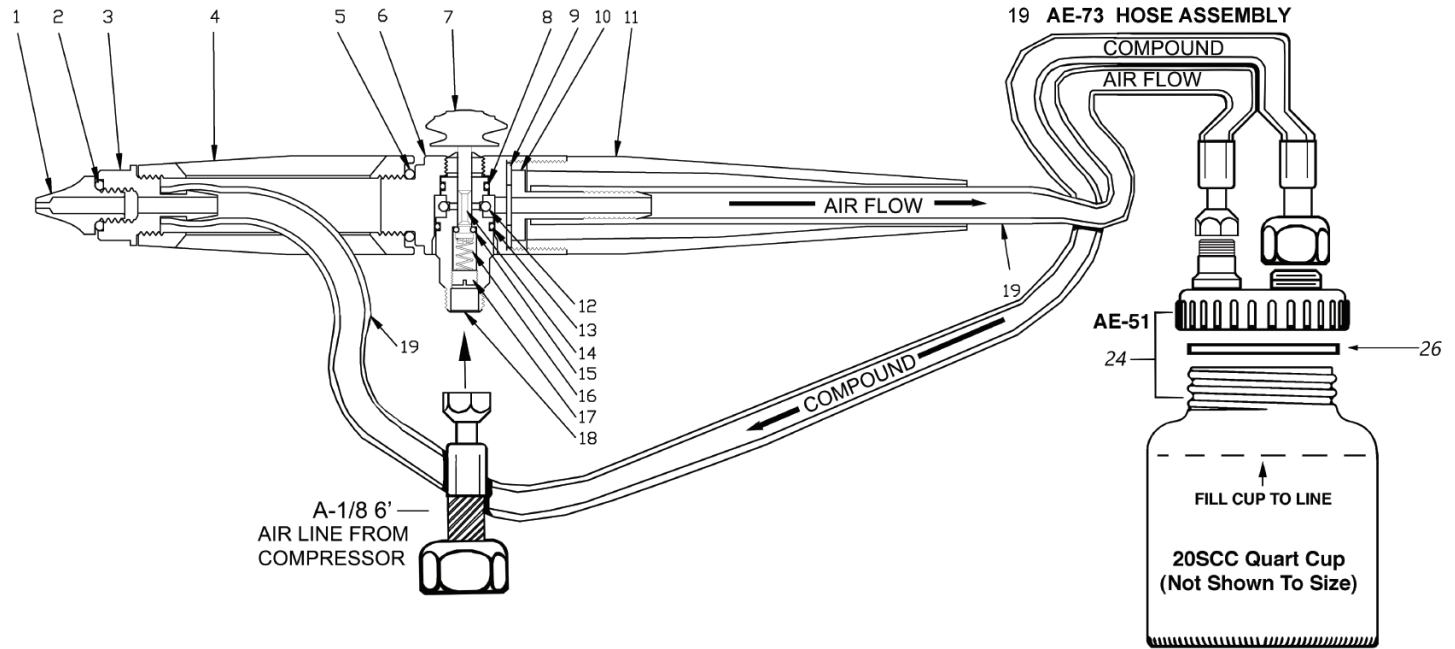

No.	Part No.	Description
1.	AEC-34R	Tip w/Carbide Insert
2.	AE-43	"O" Ring
3.	AE-71	Adapter
4.	AE-72	Tube
5.	AE-6	"O" Ring
6.	AE-70	Shell
7.	H-155	Button
8.	TAL-22	"O" Ring
9.	AE-59	Gasket
10.	AE-49	Hose Connection
11.	AE-48	Handle
12.	AE-68	"O" Ring
13.	AE-69	"O" Ring

14.	AE-64	Plunger
15.	A-53	"O" Ring (Pack of 6)
16.	A-22	Valve Spring
17.	A-23R	Air Valve Nut
18.	AE-63	Valve Casing
19.	AE-73	Hose Assembly (connection to cup)
	A-1/8-6	Air Hose
24.	AE-51	Cover Assembly w/Fittings
26.	7-GN	Gasket
30.	20SCC	Quart Cup